

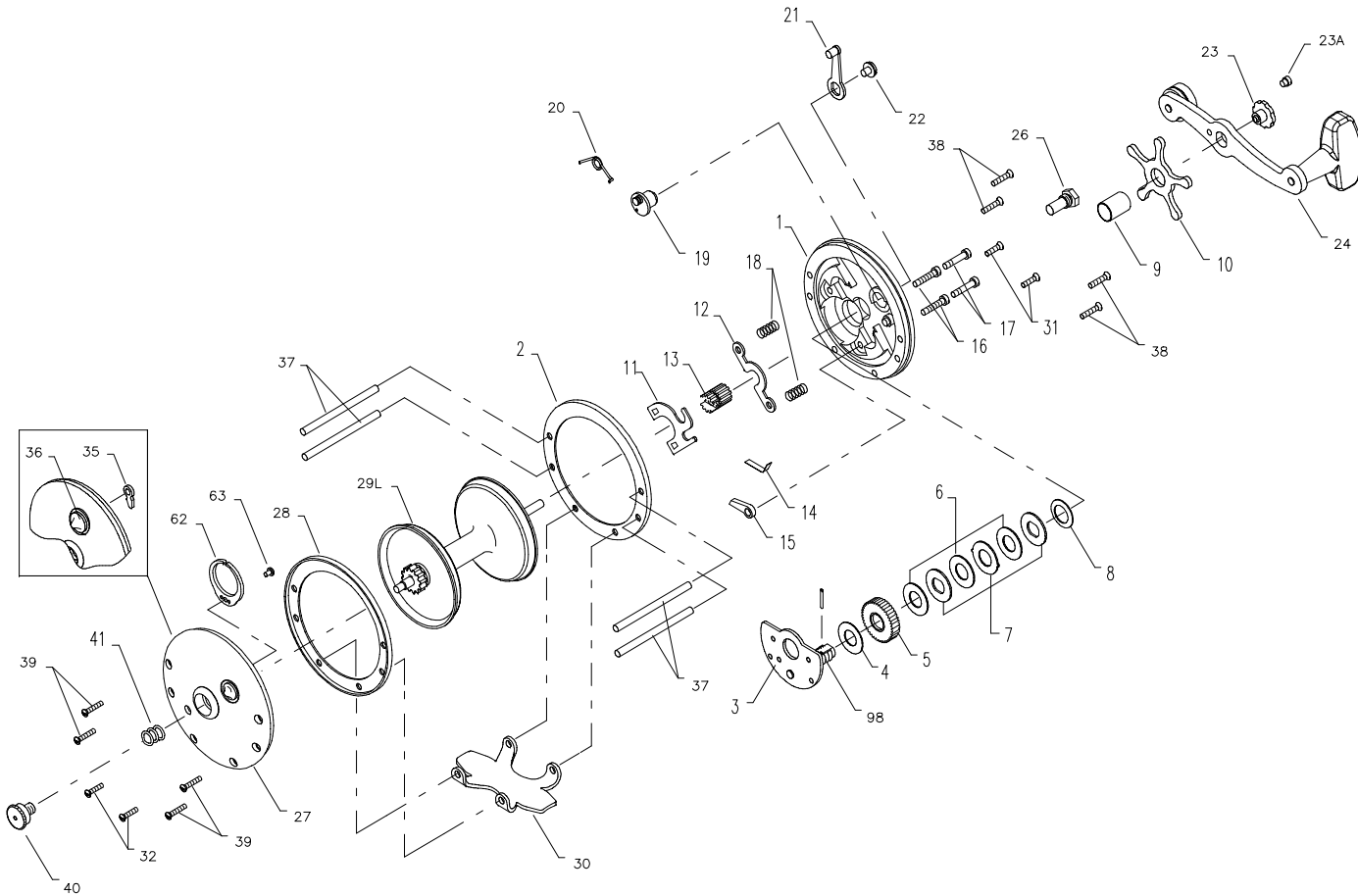

PARTS LIST FOR MODELS 155L AND 160L



KEY NO.	PART NO.	DESCRIPTION
1	001 155	Right Side Plate
	001 160	Right Side Plate
2	002 155	Right Side Ring
3	003 155	Bridge w/Sleeve
4	004 155	Fiber Washer
5	005 155	Main Gear
6	006 155	Drag Washer (3 req.)
7	007C155	Metal Washer Set
8	008 060	Tension Spring
9	009 060	Spacing Sleeve
10	010 060	Star Drag Wheel
11	011 155	Eccentric Jack
12	012 155	Pinion Yoke
13	013 155	Pinion
14	014 155	Dog Spring
15	015 155	Dog
16	016 060	Lower Bridge Screw
17	017 060	Upper Bridge Screw
18	018 060	Clutch Spring
19	019 155	Eccentric
20	020 155	Eccentric Spring
21	021 155	Eccentric Lever
22	022 060	Eccentric Screw
23	023 060	Handle Screw
23A	110 060	Handle Lock Screw
24	024 155	Handle
	024 160	Handle
26	026 155	Right Side Bearing
27	027 155	Left Side Plate
28	002 155	Left Side Ring
29	029L200	Spool (155L)
	029J150	Spool (160L)
30	030 155	Stand
	030 065	Stand (160L)
31	032 022	R.S. Stand Screw (2 req.)
32	032 014	L.S. Stand Screw (2 req.)
35	035 155	Click Tongue
36	036 155	Click Button
37	037 155	Frame Post
	037 160	Frame Post
38	038 008	Right Side Post Screw (4 req.)
39	038 008	Left Side Post Screw (155L) (4 req.)
	039 004	Left Side Post Screw (160L) (4 req.)
40	040 060	Left Side Bearing
41	041 060	Left Side Bearing Spring
62	062M209	Click Spring
63	031 2.5FR	Click Spring Screw
98	098 155	Gear Sleeve